

## WORKMASTER

is a flexible modular automation system consisting of a changing unit which changes large and small pallets between the magazines and up to four machines in the same production cell.

Several designs of magazine are available. The basic variants are modular racks or rotating magazines, where the shelves are matched to the pallet systems in System 3R's wide range of products.

Typical fields of application are:

- ▶ milling – changing of workpiece and cutting tool
- ▶ grinding – changing of workpieces
- ▶ die-sinking EDM – changing of workpieces and electrodes
- ▶ wire EDM – changing of workpieces

## TECHNICAL SPECIFICATION

- Transfer weight – pallet with workpiece 75 kg or 150 kg, electrodes 10 kg
- X-, Z- and C-axes – AC servomotor
- Max stroke, X-axis, 1250 mm
- Stroke, Z-axis – 1400 mm
- Rotation, C-axis, 300 degrees
- Power supply required: three-phase 400 V AC, 3.5 kVA
- Air pressure required –  $6 \pm 1$  bar, 150 l/min
- Interface - serial R232/422, M-function or parallel I/O

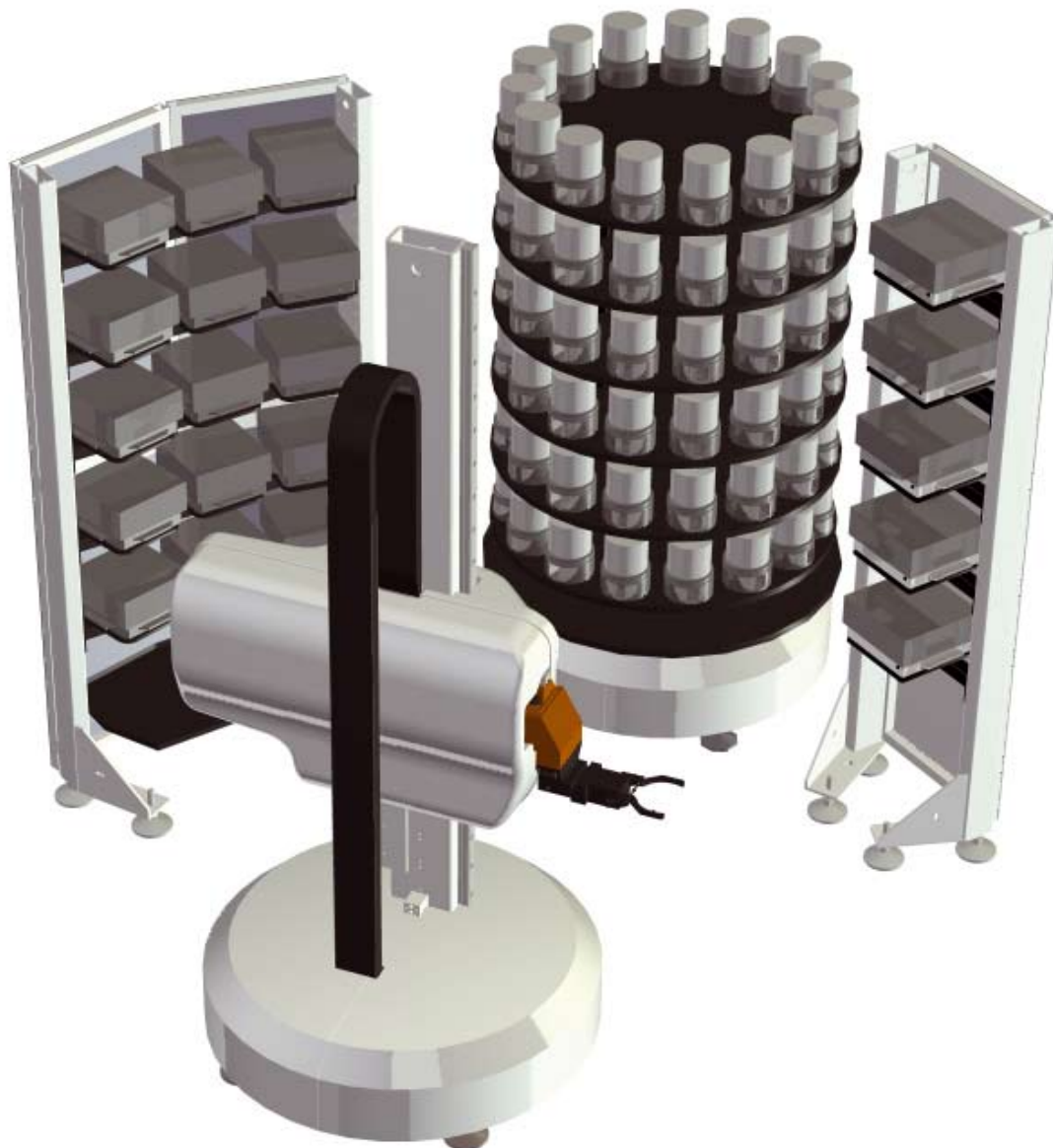

## MODULAR MAGAZINES GIVE FLEXIBILITY

The magazines are available in two basic designs – rack or rotary. In both cases they are matched to System 3R's pallet system. Each magazine unit consists of a number of shelves. The number is determined by the height of the workpieces in

question. Because of the modular design, you can start with fewer pallet positions. When the need arises, you can add one or more magazine units to increase the production capacity in step with the growth of your business.

### Half rack magazine

- Five levels
- Maximum load per level – 150 kg
- Maximum total load – 1200 kg
- ▶ Option – door for loading from behind
- ▶ Option – more shelves

| Tool system | Number of positions per shelf | Maximum dimensions workpiece |
|-------------|-------------------------------|------------------------------|
| GPS240      | 1                             | 450 x 450 mm                 |
| Dynafix     | 1                             | 450 x 450 mm                 |
| Delphin     | 1                             | 450 x 450 mm                 |
| MacroMagnum | 1                             | 200 x 200 / Ø200 mm          |



### Full rack magazine

- five levels (standard)
- Maximum load per level – 300 kg
- Maximum total load – 1200 kg
- ▶ Option – door for loading from behind
- ▶ Option – more shelves

| Tool system     | Number of positions per shelf | Maximum dimension workpiece |
|-----------------|-------------------------------|-----------------------------|
| MacroJunior     | 21                            | 45 x 45 / Ø45 mm            |
| Macro 54 och 70 | 12                            | 70 x 200 / Ø80 mm           |
| GPS70           | 12                            | 70 x 200 / Ø80 mm           |
| Macro Ø116      | 6                             | 150 x 150 / Ø160 mm         |
| GPS120          | 6                             | 150 x 150 / Ø160 mm         |
| MacroMagnum     | 5                             | 170 x 170 / Ø185 mm         |
| GPS240          | 3                             | 275 x 275 mm                |
| GPS240          | 2                             | 400 x 400 mm                |
| Dynafix         | 2                             | 400 x 400 mm                |
| Delphin         | 2                             | 400 x 400 mm                |



In **wire EDM**, only customer-specific solutions, since the number of positions per shelf is determined mainly by the size of the workpiece and therefore of the clamping elements and not by the tool system – whether you choose Macro, Unimatic or MacroTwin.

## Rotary magazine

- Maximum total load – 1000 kg

| Tool system | Number of positions per shelf | Maximum dimensions workpiece |
|-------------|-------------------------------|------------------------------|
| Macro Ø116  | 20                            | 135 x 135 / Ø150 mm          |
| GPS120      | 20                            | 135 x 135 / Ø150 mm          |
| MacroMagnum | 15                            | 160 x 160 / Ø190 mm          |
| GPS240      | 6                             | 280 x 280 mm                 |
| Dynafix     | 6                             | 280 x 280 mm                 |

In **wire EDM**, only customer-specific solutions, since the number of positions per shelf is determined mainly by the size of the workpiece and therefore of the clamping elements and not by the tool system – whether you choose Macro, Unimatic or MacroTwin.



## Indexing magazine

- Maximum total load – 1000 kg

| Tool system     | Number of positions per shelf | Maximum dimensions workpiece |
|-----------------|-------------------------------|------------------------------|
| MacroCombi      | 60                            | 44 x 44 / Ø44 mm             |
| Macro 54 och 70 | 32                            | 65 x 65 / Ø90 mm             |
| GPS70           | 32                            | 90 x 90 / Ø95 mm             |

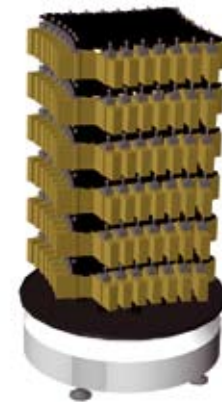

## WPS – preparation station / loading station

Station for the preparation of workpieces. The station has a door and side guards. Fencing is not needed. A chuck is not included.

- Maximum workpiece dimensions – 450x450x450 mm
- Maximum load – 200 kg
- Collection tray for oil and flushing liquid
- Presence monitoring
- Prepared for chuck installation, including foot control and pneumatic connections
- ▶ Option – manual flushing liquid sensor
- ▶ Manual indexing unit, 4x90 degrees, with locking device
- ▶ D antenna, fixed

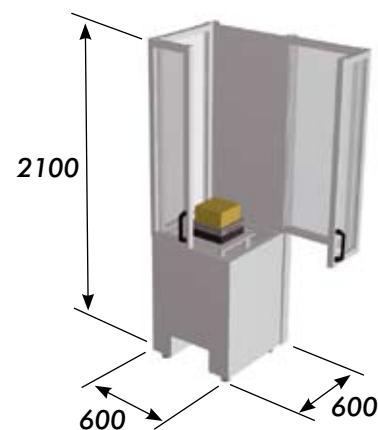

## GROWS WITH THE NEED

WorkMaster has enough capacity to serve more than one machine. One machine, two machines, three machines or four machines! Machines of the same type and make, or machines with different machining technologies and of different makes. WorkMaster has an open architecture, bringing them all together under one roof. Always with the focus on flexibility and productivity. The possibilities are endless.

## Options

- ▶ Gripper jaw with tipping function
- ▶ Gripper jaw with rotary function
- ▶ Double gripper jaw
- ▶ Tipping arm
- ▶ Loading stations
- ▶ Draining station
- ▶ Drying station
- ▶ Chuck adapters
- ▶ ID system with/without automatic scanning
- ▶ Cell PC with WorkShopManager software

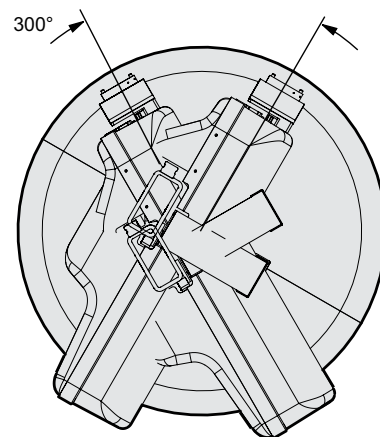
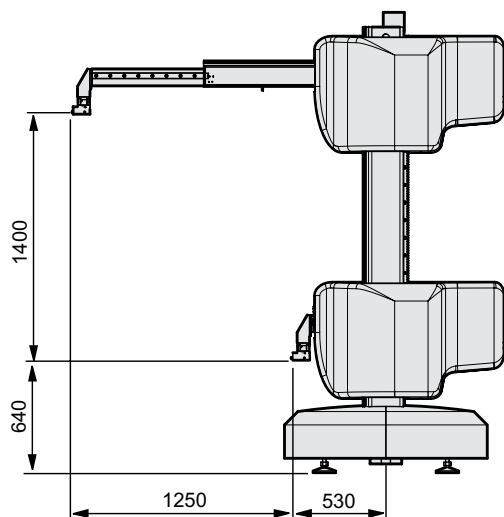
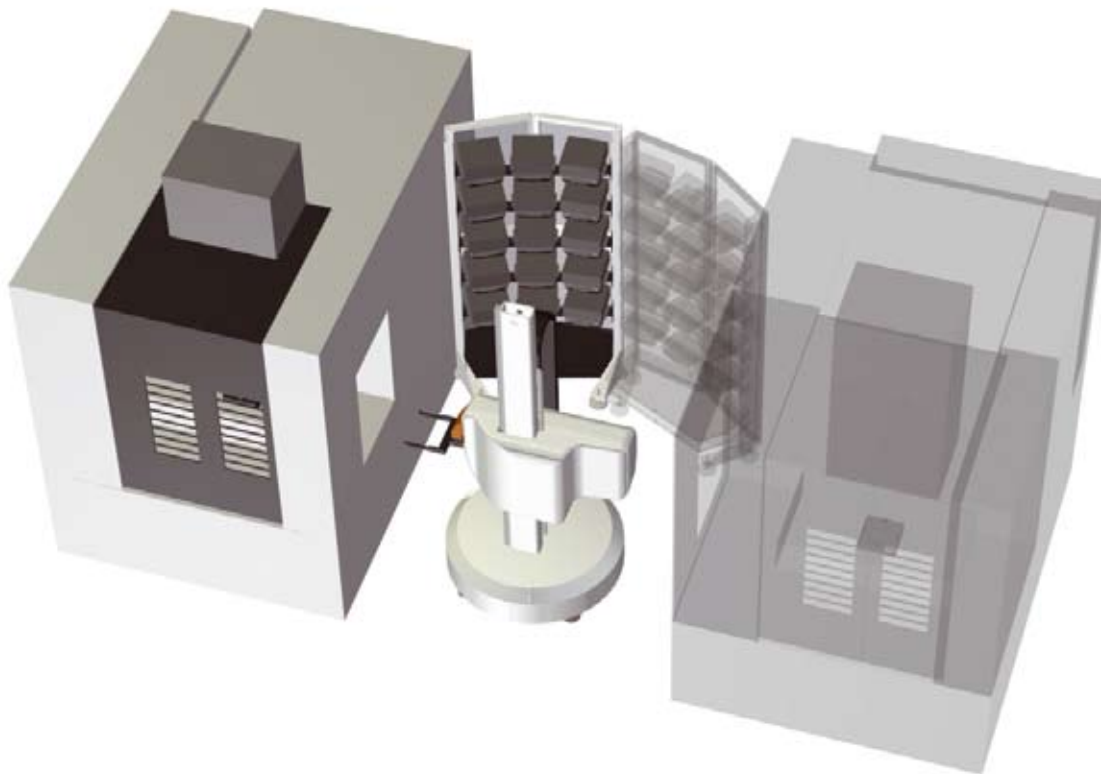

## System 3R International AB

Sorterargatan 1, SE-162 50 VÄLLINGBY

tel +46-08 620 20 00, fax +46-08 759 52 34, e-mail: info@system3r.com, www.system3r.com

### ASIA

**Far East, China & India**  
**System 3R Far East Pte.Ltd.**  
6 Harper Road  
Leong Huat Building, 01-01  
SINGAPORE SG-369 674  
tel +65-6289 4811  
fax +65-6289 3011  
e-mail info.sg@system3r.com

**Shanghai Contact Office**  
tel +86-21 6432 7927  
fax +86-21 6432 7928  
e-mail info.cn@system3r.com

**Beijing Contact Office**  
tel +86-10 8225 1632  
fax +86-10 8225 1635

**Guangdong Contact Office**  
tel +86-769 8162 0628  
fax +86-769 8162 0638

**Malaysia Contact Office**  
tel +60-03 7877 4785  
fax +60-03 7877 5948

**Taiwan Regional Office**  
tel +886-02 2278 3126  
fax +886-02 2278 3108

**Thailand Contact Office**  
tel / fax +66-2 6422 764

**Japan & Korea**  
**System 3R Japan CO., Ltd.**  
Kaki Building  
2-5-22, Suido, Bunkyo-ku  
TOKYO JP-112-0005  
tel +81-03 5840-7383  
fax +81-03 5848-8723  
e-mail info.jp@system3r.com

**Nagoya Regional Office**  
tel +81-052 774 6250  
fax +81-052 774 6285

**Osaka Regional Office**  
tel +81-06 6396 1500  
fax +81-06 6396 2855

### EUROPE

**System 3R Europe GmbH**  
Wasserweg 19  
DE-64521, GROSS-GERAU  
tel +49 61 52 80 02 0  
fax +49 61 52 80 02 35  
e-mail info.eu@system3r.com

**Czech Republic & Slovakia**  
**System 3R Czech**  
Tiskarska 10/257  
CZ-108 28 PRAHA 10  
tel +420 234 054 224  
fax +420 234 054 225  
e-mail info@system3r.cz

**France & Portugal**  
**System 3R France**  
56 Boulevard de Courcerin  
Les Espaces Multiservices 15  
F-77183 CROISSY BEAUBURG  
tel +33-01 60 95 90 80  
fax +33-01 60 37 88 16  
e-mail info.fr@system3r.com

**Germany & BeNeLux**  
**System 3R Deutschland**  
Wasserweg 19  
DE-64521, GROSS-GERAU  
tel +49 61 52 80 02 0  
fax +49 61 52 80 02 35  
e-mail info.de@system3r.com

**Italy & Spain**  
**System 3R Italia**  
Via Ponchielli, 2/4  
IT-20063 CERNUSCO SUL NAVIGLIO (MI)  
tel +39 02 92 38 821  
fax +39 02 92 11 23 19  
e-mail info.it@system3r.com

**Scandinavia**  
**System 3R Nordic**  
Sorterargatan 1  
SE-162 50 VÄLLINGBY  
tel +46-08 620 20 00  
fax +46-08 38 81 84  
e-mail info.no@system3r.com

**Järfälla Hårdverkstad**  
Elektronikhöjden 8  
SE-175 43 JÄRFÄLLA  
tel +46-08 580 125 50  
fax +46-08 580 126 55  
e-mail info@jhw.se

**Switzerland & Austria**  
**System 3R Schweiz AG**  
Wilerstrasse 98  
CH-9230 FLAWIL  
tel +41-071 394 13 50  
fax +41-071 394 13 60  
e-mail info.ch@system3r.com

**Turkey & Bulgaria**  
**System 3R Türkiye**  
Abdi İpekçi Cad. Özel İdare İş Merk 150/209  
Bayrampasa 34030 İSTANBUL  
tel +90-212 613 8062-8063  
fax +90-212 613 8069  
e-mail system3r@superonline.com

**United Kingdom**  
**System 3R UK**  
Redvale House, New Road  
PRINCES RISBOROUGH, Buckinghamshire  
HP27 0JN United Kingdom  
tel +44-01844 27 44 55  
fax +44-01844 34 88 00  
e-mail info.uk@system3r.com

### AMERICA

**System 3R USA Inc.**  
Headquarters & Technical Center  
915 Busse Road  
ELK GROVE VILLAGE, US-IL 60007  
tel +1 847 439 4888  
fax +1 847 439 5099  
e-mail: info.us@system3r.com

**Canada & Eastern MI**  
116 Lynngate Place  
London Ontario Canada N6K  
1S5  
Canada  
tel +1 519 870 8339, +1 248 320 1016  
e-mail: ted.bilous@system3r.com

**AZ, CA, CO, ID, MT, NM, NV, OR, TX,  
UT, WA, WY & Mexico**  
1241 Celery Lane  
Corona, US-CA 91719  
Tel +1 909 226 1042  
e-mail: ben.avila@system3r.com  
1524 Valley Dr.  
Norco, US-CA 92860  
tel +1 714 299 4923  
e-mail: dennis.vanhine@system3r.com

**IA, MN, ND, NE, SD & WI**  
915 Busse Road  
Elk Grove Village, US-IL 60007  
tel +1 847 439 4888, +1 630 240 9825  
fax +1 847 439 5099  
e-mail: dan.pilolla@system3r.com

**AR, IN, KY, OH & TN**  
8466 Hill Pine Court  
Indianapolis, US-IN 46227  
tel +1 317 215 4039, +1 317 694 7508  
fax +1 317 215 4041  
e-mail: jim.norcross@system3r.com

**AL, FL, GA, LA, MS, NC & SC**  
20934 Orchard Town Ave.  
Land O Lakes, US-FL 34638  
tel +1 813 326 0125  
e-mail: reuben.romney@system3r.com

**IL, KS, MO, OK & Western MI**  
915 Busse Road  
Elk Grove Village, US-IL 60007  
tel +1 847 439 4888, +1 630 240 9824  
fax +1 847 439 5099  
e-mail: anders.utterstrom@system3r.com

**NJ, NY & PA**  
67 Forest Drive  
Pompton Plains, US-NJ 07444  
tel +1 201 248 3885  
e-mail: frank.johnson@system3r.com

**CT, DC, DE, MA, MD, ME, NH, RI, VA,  
VT & WV**  
915 Busse Road  
Elk Grove Village, US-IL 60007  
tel +1 847 439 4888, +1 201 214 7088  
fax +1 847 439 5099  
e-mail: jack.sebzda@system3r.com

**system 3R** the Pioneer

**+GF+**

Combi, Delphin, Dynafix, Lock, LX, Macro, One Minute Set-Up, One System Partner, R2R, System 3R, VDP, WorkMaster, WorkPal, WorkPartner, WorkShopManager, 3HP, 3R, 3Ready-To-Run and 3Refix are registered trademarks of System 3R.

# WorkMaster

