

AUTOMATION



The leading supplier of
factory automation

Automation pays off – always!

Automation ensures that you get the best possible benefits from your production machinery and that your machines and systems will achieve the highest possible output from the 8760 production hours available each year. Automation pays off – just let us show you how...

Fastems is your committed long-term partner when it comes to factory automation. As an open system integrator, we offer a variety of extendable and flexible FM systems and robots, advanced MMS controls, stacker cranes, loading and material stations – supported with world-class service.

With these elements you can integrate a wide selection of machines, tools, robots, as well as other value-adding devices. Standard or customised, these solutions will take you even closer to achieving the full 8760 production hours.

More unmanned hours with

- Enhanced availability through workshop-tested hardware and software modules
- Effective space utilisation through multi-level storage solutions
- Fast installations for fewer production breaks

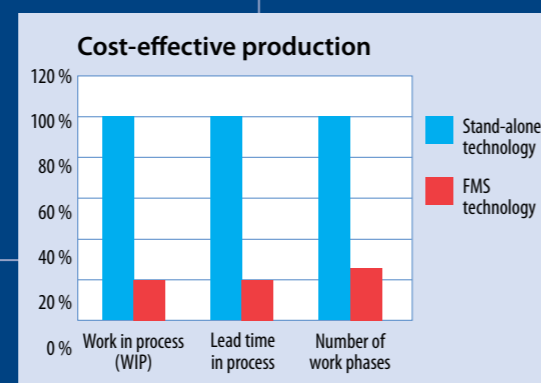
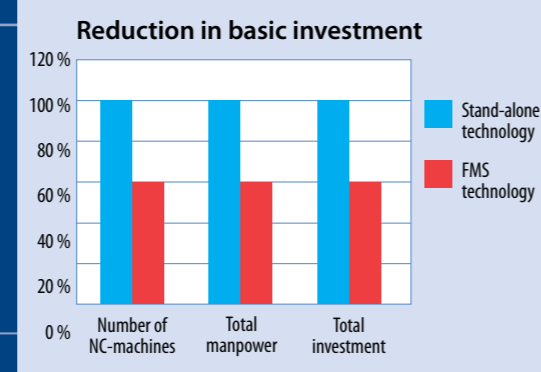

- ### Achieve clear benefits
- More hours with fewer machines
 - High availability guaranteed for the system
 - Freedom to select machine tools from any major supplier
 - Standard modules to fulfill your specific requirements
 - User-friendly control system
 - A quick return-on-investment
 - Reduction of work in process (WIP)



FAO delivers the best architecture

The Fastems Assembly Organizer, FAO delivers top architecture both in the physical factory environment and in the selection of control options. Built around the Fastems MLS system, this factory-in-factory solution integrates everything from parts machining, and assembly functions to raw material, component and finished product inventories, as well as order-based parts sampling and tailored reporting.

MLS – maximised flexibility

For maximised flexibility, Fastems Multi-Level-System, MLS allows you to integrate machines of different sizes and ages, and also to shift pallets for billets or pallets for other process materials. Get it as standard with a variety of options, or tailored to your specific needs.

FPM – a full package for versatility

Fastems Flexible Pallet Magazine FPM, offers versatility in size, machine number and control features. Designed to realise your basic integration demands, it helps you strive for the 8760 annual production hours – partly unmanned.

FPC – expandable and cost-effective

Our Flexible Pallet Container, FPC, is a standard solution for integrating up to two equal machines in a smart way. Up and running in a day, FPC provides you with a cost-effective head start towards the 8760 production hours a year.

Pay back starts with a robot...

A robot pays off in about 1,000 working hours. Just try one of our factory-ready RPC or RPC-G cells and apply them to lathes and vertical machining centres to see how they pay back.

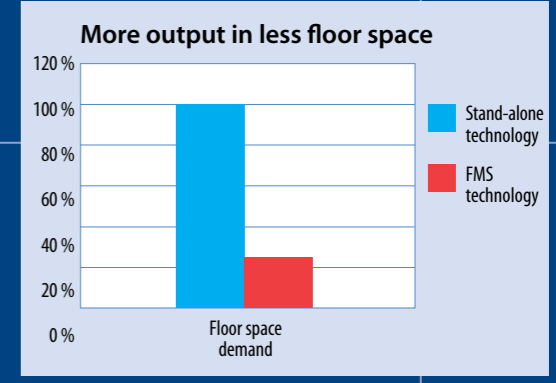

Pay back starts with a robot..

Fastems modular robot cells create a natural first step for your factory automation. Our robot cell family comprises NC machine tool tending cells, deburring cells, as well as customised cells for various purposes.



RPC-165

Gain with RPC:

- Quick pay back on investment
- More capacity due to unmanned hours
- More effective use of resources
- Suitable for small batch production
- Easy changing of product batches
- Wide selection of auxiliary devices
- Standard options to extend the basic solution
- Integration also with existing machinery
- Quick and easy installation

DBL automates your deburring process

Fastems DBL (Deburring and Loading Cell) was developed for automatic deburring and loading applications. This modular robot cell automates the uncomfortable and difficult deburring process, making dusty, noisy and monotonous work a thing of past. At the same time, it maintains consistent deburring quality.



RPC-70G is extendable with standard modules e.g. lengthening of linear track and additional trolley stations for material buffering.

RPC enhances production efficiency

The RPC (Robotised Production Cell) enables you to increase the utilisation rate of your existing machinery with a small investment. Designed to work with various CNC machines, such as lathes, machining centres and other machine tools, the modular RPC helps you cope with large variations in production volume. With standard options RPC can be easily adapted to other applications including workpiece finishing and gauging. Furthermore, RPC allows you to quickly and easily adapt to today's rapidly changing production requirements, offering operators more freedom for parts handling.

The RPC family includes:

- RPC-20 (20 kg payload)
- RPC-20G (20 kg payload, gantry type cell)
- RPC-70 (70 kg payload)
- RPC-70G (70 kg payload, gantry type cell)
- RPC-165 (165 kg payload)

DBL provides you with a standard and modular solution that solves deburring problems for the entire production process. The unit offers all the tools needed for efficient deburring in various applications.

DBL highlights:

- Designed for continuous unmanned production
- Maintains top quality constantly
- Reduced WIP due to higher throughput
- Improved safety and work ergonomics
- Integrated or stand-alone installation
- Transferable unit, easy to install and relocate

Customised robot cells

When you need to automate an entire workpiece handling and finishing cycle, customised RPC is your solution. Besides machine tool tending, your process may require washing cycle or surface finishing. And to gain full advantage of robotising, these phases have to be automated, as well. Customised robot cells are based on RPC basic modules integrated with the necessary customer-specific features.



RPC-165C

With a full selection of features:

- Several machine tool interfaces
- Interface to washing or gauging
- Interface to Fastems FMS (Flexible Manufacturing System)
- Special machine interfaces such as marking machine, screwing machine and simple assembly machines
- Customised robot cells are based on RPC basic modules integrated with the necessary customer-specific features



DBL-165

RPC-20G is an easy-to-use, space saving solution offering all the benefits of a robot cell plus it leaves the front of the lathe free.

Technical information:

Robot cell type	RPC-20	RPC-20G	RPC-70	RPC-70G	RPC-165	DBL-165
Max. payload	20 kg	20 kg	70 kg	70 kg	165 kg	165 kg
Material buffer	2 off trolley platform 600 x 800 mm/ 23,6 x 31,5 in	2 off trolley platform 1200 x 800 mm/ 47,2 x 31,5 in	2 off trolley platform 1200 x 800/ 47,2 x 31,5 in	2 off trolleys (3 as an option) platform 1200 x 800 mm/ 47,2 x 31,5 in	3 off trolley platform 1200 x 800 mm/ 47,2 x 31,5 in	Trolleys Servo table
Machine tending applications	√	√	√	√	√	NAO
Deburring applications	Optional	NAO	Optional	NAO	Optional	√
Machine tools integrated	1	1	1	1 (2 as an option)	2	NAO
Integration to FMS	Optional	Optional	Optional	Optional	√	√
Cell dimensions (L x W x H)	2600 x 2400 x 2500 mm 102,4 x 94,5 x 98,4 in	5040 x 2150 x 2740 mm 198,4 x 84,6 x 107,9 in	3600 x 2400 x 2500 mm 141,7 x 94,5 x 98,4 in	10500 x 2750 x 3150 mm 413,4 x 108,3 x 124,0 in	4100 x 3400 x 2470 mm 161,4 x 133,9 x 97,2 in	4600 x 3400 x 3000 mm 181,1 x 133,9 x 118,1 in
Transportable as one unit	√	√	√	-	-	-
Machine vision	Optional	Optional	Optional	Optional	Optional	Optional
Integration to auxiliary equipment (washing, measuring)	√	Optional	√	√	√	√

NAO = Not Available Option

FPC – expandable and cost-effective

Our Flexible Pallet Container, FPC, is a standard solution for integrating up to two identical machine tools in a smart way.

A wide variety of advanced features:

- Compact and safe design
- Extendable up to a two-machine system
- Same day installation and start-up
- Easy to transport to the site in one piece
- Easy to move during factory layout changes
- Advanced FPC Cell Controller for unmanned operations

An intelligent investment

The FPC allows machine suppliers to sell expandable solutions in accordance with customer plant requirements. The base system is easy to expand with additional pallets, machine tools, and new container units to better meet future challenges.

Compared to conventional pallet pools, the FPC is an economical way to add more production capacity. FPC provides machine tool manufacturers with an excellent opportunity to sell expandable solutions with low investment costs. For instance, FPC is the optimum choice for component manufacturers with diverse or large production series and changing needs.

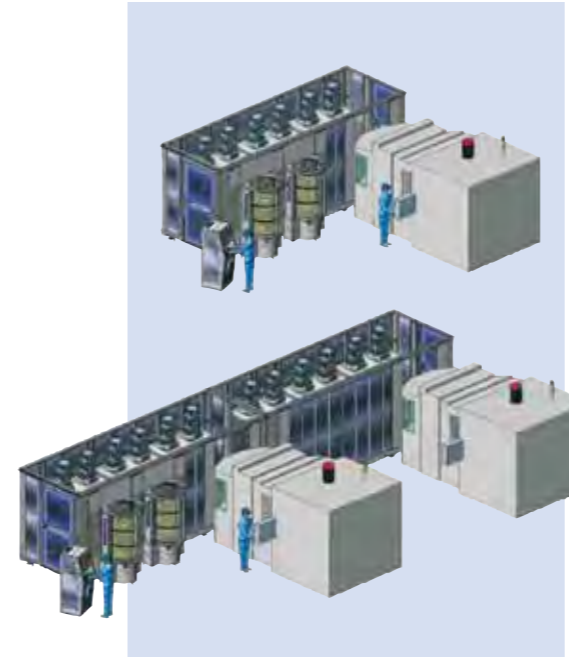

Extension to two machine system possible.



FPC-750 with ergonomic loading stations.



Storage view with stacker crane.

Container

Storage places on up to 2 levels. Coolant plates lead the coolant to a central coolant basin that is equipped with a pneumatic pump.

FPC - Control System

The control system is independent of the machine tool control. The software is based on full-sized FMS software. A Fastems interface to the machine control is necessary for data exchange with the machine tool.

Stacker Crane

Transports machine pallets: carries the pallets with a parallelogram mechanism.

Machine Tool

- FPC is an open solution and can be integrated with several brands of machine tools.
- Machine needs to be equipped with pallet changer.
- Only one machine type can be connected to each container system.
- One machine can be connected to each container unit.
- Fastems needs to check the pallet handling for the connected machine.

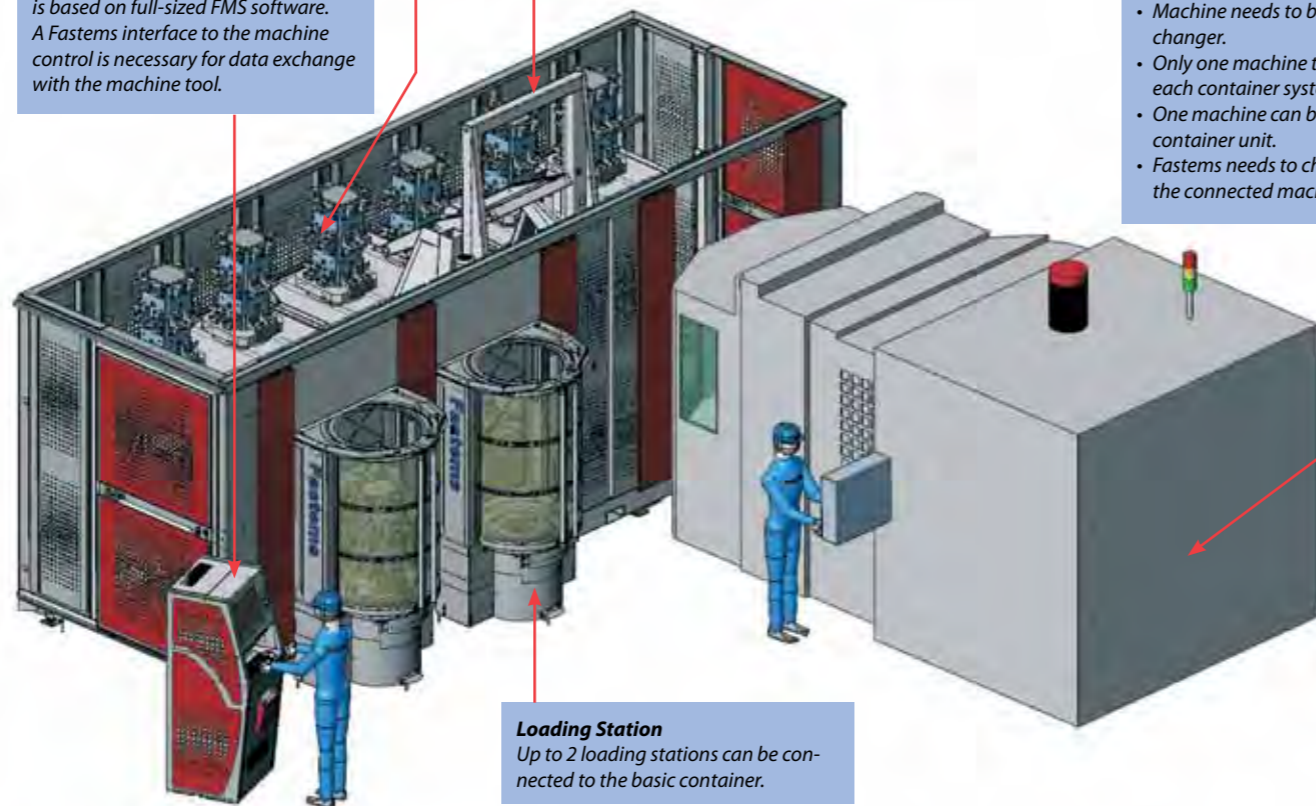

Loading Station

Up to 2 loading stations can be connected to the basic container.

FPC – a cost-effective investment

The FPC provides machine suppliers with a complete FMS installed in a 'container' and designed for a specific machine tool type. Each FPC contains all the equipment required for an automated pallet storage and handling system.

This Fastems innovation provides an advanced and cost-effective alternative to conventional pallet pools, turning your machining centre into an automated FM system.

Technical information:

System type	FPC-750	FPC-1000	FPC-1500	FPC-3200
Nominal Load capacity (kg)	750	1000	1500	3200 ¹⁾
Nominal Machining Pallet Size	400 x 400 mm	500 x 500 mm	630 x 630 mm	800 x 800 mm
	500 x 500 mm	630 x 630 mm	630 x 800 mm	1000 x 1000 mm
	15,7 x 15,7 in	19,7 x 19,7 in	24,8 x 24,8 in	31,5 x 31,5 in
	19,7 x 19,7 in	24,8 x 24,8 in	24,8 x 31,5 in	39,4 x 39,4 in
- different sizes in same system	NAO			
Material Pallets	NAO			
Control System	Fastems MMS Control System			
- options	std. FPC option list			
Number of pallet places in base system	12	10	10	4
- with extension module	24	20	20	8

NAO = Not Available Option

¹⁾ Load handling needs to be performed from below the pallet. Otherwise the total load weight (incl. pallet) is less than 3200 kg

FPM – a new standard for flexibility

The Fastems Flexible Pallet Magazine, FPM, is a configurable, flexible manufacturing system that offers you versatility in size, number of machines and control features. The new FPM is ready to enhance your productivity with several new features.

A full package for versatility

The Flexible Pallet magazine provides a cost effective alternative for more flexibility, when the tailored MLS system seems too big an investment and the FPC container is not quite enough anymore. Based on standard modules with configurable options, FPM creates an ideal and easily affordable solution for machining workshops to increase their automation level and unmanned production.

Made to be effective

The new generation FPM has been designed with special focus on quick installation and easy maintenance, and Fastems can also support you with a comprehensive service package. In addition, a new control system provides FPM users with an easy-to-learn and easy-to-use graphical interface. Whatever your needs, the modular system can grow together with your production goals – as far as your vision can take you.

The base system consists of:

- 2- or 3-level storage on one side
- Stacker crane
- LSF loading station
- A machine tool interface
- Fastems FPM control system

The base system can be extended with a wide range of options and Fastems support services.



Efficient FPM stacker crane.

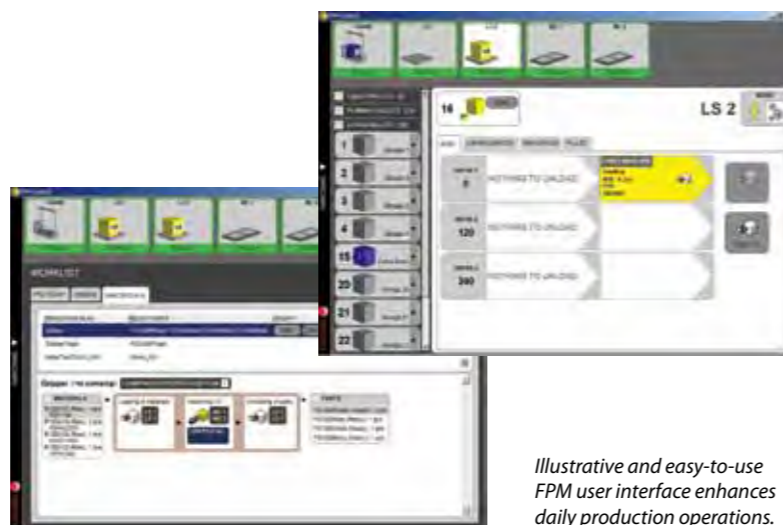

Illustrative and easy-to-use FPM user interface enhances daily production operations.

Gain clear benefits:

- High availability
- Efficient space utilisation
- Modular design
- Simple operation
- Minimal service requirements
- Extendable from a single machine cell into a full-scale FMS line
- Short delivery time with quick installation and start-up

Technical information:

System type	FPM-750	FPM-1100	FPM-1700
Nominal Load capacity (kg)	750	1100	1700
Nominal Machining Pallet Size	400x400 mm	500x500 mm	630x630 mm
	400x500 mm	500x630 mm	630x800 mm
	15,7 x 15,7 in	19,7 x 19,7 in	24,8 x 24,8 in
	15,7 x 19,7 in	19,7 x 24,8 in	24,8 x 31,5 in
- different sizes in same system	NAO		
Material Pallets	NAO		
Control System	Fastems FPM Control System		
- options	std. FPM option list		
Number of pallet places in base system			
2-level	16	12	8
3-level	24	18	12
- with standard extensions			
2-level	+n x 8	+n x 6	+n x 4
3-level	+n x 12	+n x 9	+n x 6

NAO = Not Available Option

MLS – maximised flexibility



The MLS is designed to ensure the efficient use of a production facility of any size or height.

Easy integration

The MLS system integrates easily with a variety of machine tools and auxiliary equipment. You can integrate machines that have different pallet sizes or different table heights. The system also enables integration of material management programs, manually operated machines, robot cells, as well as various other production devices.

Tailored to your needs

- MMS controls with free selection of control options
- DNC-interface and resource management functions
- Any pallet size/several pallet sizes in the same system
- Load weight up to 10,000 kg
- Material pallet handling in the same system
- Material transport on standard EUR or special material pallets

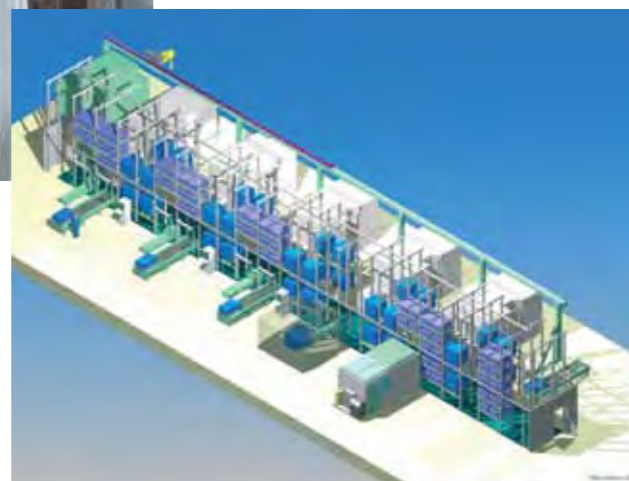

Tailored to your needs with no limits.

Multi-level storage capacity is the main idea behind all of Fastems' FM systems. The Multi Level System (MLS), with its large storage capacity and minimal floor space requirements, can increase your productivity and let your FMS grow as high as your production goals take you.



With full benefits:

- Compact, modular, expandable
- Ensures high availability and unmanned production
- Enables assembly management functions
- Large storage capacity with minimal floor space requirements
- DMC high-speed stacker crane enables short cycle times

Parts loading and unloading area of the MLS-HD system.

Technical information:

System Type	MLS-LD	MLS-MD	MLS-XMD	MLS-HD	MLS-XHD
Nominal Load Capacity (kg)	700	1500	2500	6000	max. 10 000
Nominal Machining Pallet Size	400	500	630	800	800
		500	630	1000	1000
				1250	1250
- different sizes in same system	NAO	Optional			
Material Pallets	EURO 600x800		EURO 800x1200/customer spec.		
Control System	Fastems MMS				
- options	std./customer spec.				
Number of Pallet Places of Basic Module	Not limited				
- with standard extensions	Not limited				

NAO = Not Available Option

More hours – fewer machines

Fastems provides your production line with a full range of flexible manufacturing solutions.

- Over 600 systems delivered in Europe and North America
- High availability thanks to tested hardware and software modules
- Proprietary software modules based on standard platforms (Windows®, Oracle®)
- Broad product offering – from single machine cells to assembly integrated factory-wide systems

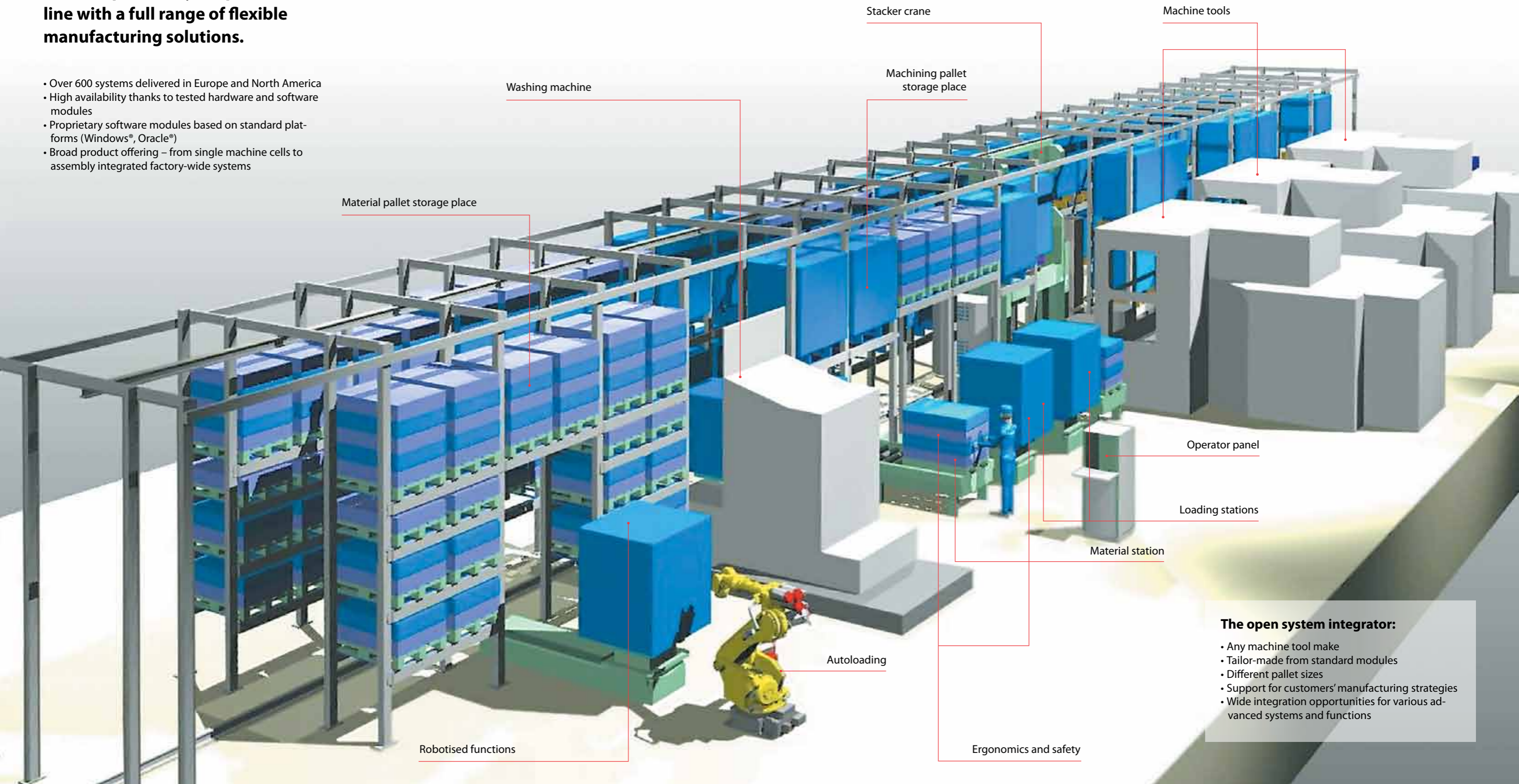

The open system integrator:

- Any machine tool make
- Tailor-made from standard modules
- Different pallet sizes
- Support for customers' manufacturing strategies
- Wide integration opportunities for various advanced systems and functions

Dependable controls from MMS



The Manufacturing Management System (MMS) is a cell controller based on standard, industry-proven software, which can be customised to meet individual production needs. The MMS cell controller is applicable to various production profiles and production types, from predictable mass production to production in small batches.

A scalable solution

The system's functionality depends on the selected software components and their specific configurations. The MMS cell controller is scalable, allowing you to start with one PC and expand your system to include more machine tools, PC computers and software applications.

Information easily at hand

The MMS supports flexible production and team organisation by providing essential production information in a clear and understandable format. It also enables immediate production start up after commissioning by minimising the need for predefined data structures and base configuration.

Quick actions, correct decisions

The main MMS functionalities are divided between process and planning application modules, which enable customers to adapt the system in response to their own production philosophies. The process module includes control applications for machine operators who work next to the machines, whereas the planning module provides information, calculation and simulation tools for those who are responsible for production planning and production management.

Adaptive scheduling

An enhanced order-based production planning system is able to determine order priorities in real time. Order priorities are automatically inherited by pallet jobs in order to ensure that at each moment the most urgent workpieces are dispatched to the machine tool.

Autopilot optimisation

The intelligent Autopilot control software selects the optimum pallet job for part clamping. The selection process is based on the availability of resources, such as raw materials and machining fixtures, as well as the current production order priority.

See the facts, analyse the results

The Production Log is a new application for managing production data. It follows the production flow of a workpiece and records which machines and programs have been used during production. It provides management with detailed information about the time spent on each order.

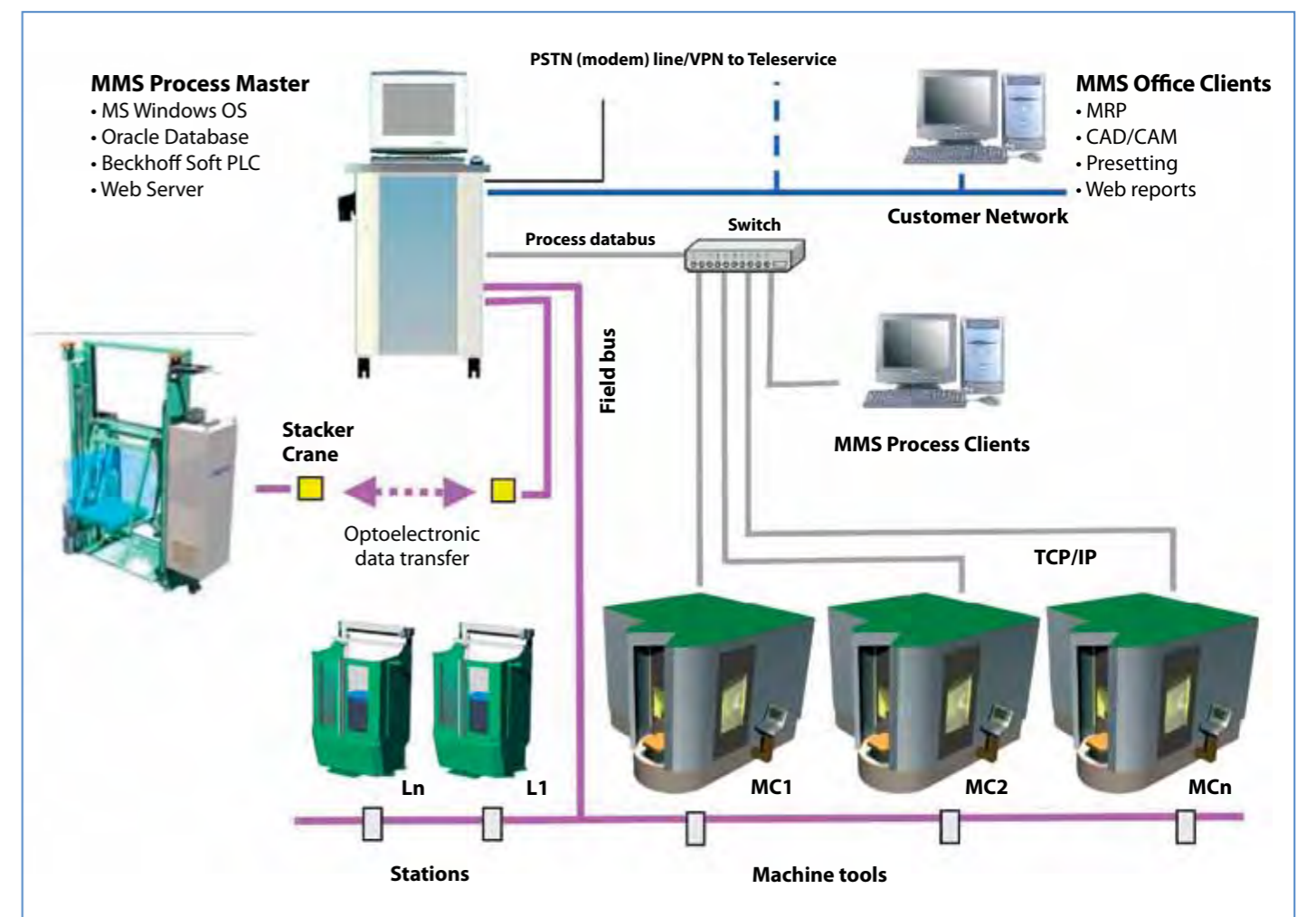
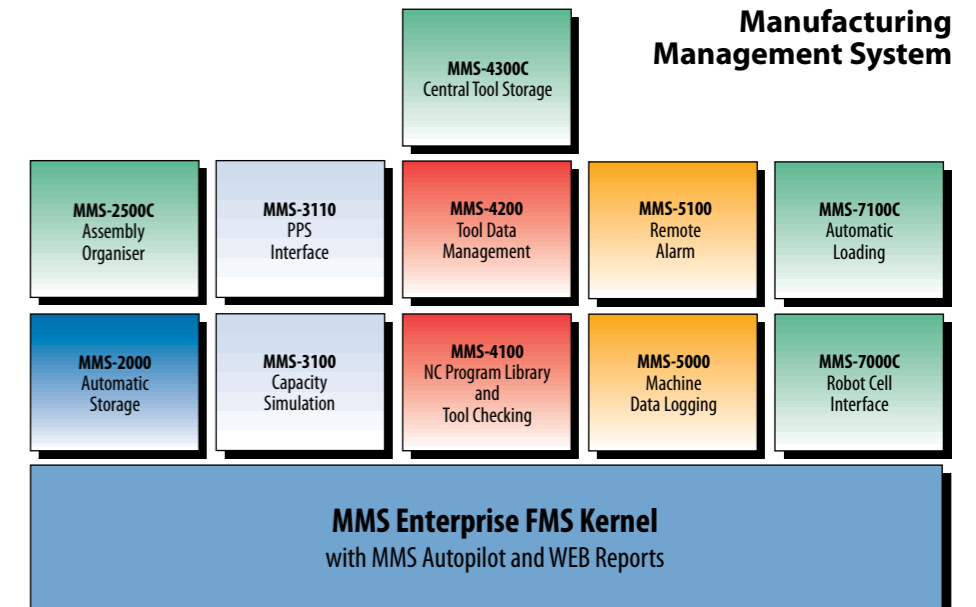

Ready for any factory height or pallet weight

Fastems' Double-Mast Stacker Cranes (DMC) operate with three numerically controlled axes. Specially designed for FMS, these stacker cranes transfer pallets between storage positions, loading stations and machine tools. Load capacities range from 700 to 10,000 kg.



DMC-HD Stacker Crane.



DMC-LD Stacker Crane.

All our stacker cranes are thoroughly tested before they leave the Fastems plant. These stacker cranes are able to handle the pallets gently without damaging the pallet surface.

- Drip trays for a clean working environment
- Smooth and accurate positioning
- Optimised velocity profiles
- Noiseless operation

DMC-LD Light Duty

- Load weight up to 700 kg
- Mainly for machine pallets
- Machine pallet sizes: from 300 x 300 to 500 x 500 mm
- Parallelogram pallet handling mechanism
- Maximum mast height 7 m

DMC-MD Medium Duty

- Maximum load weights of 1,000 or 1,500 kg
- Three different speed/performance classes: normal 2.0 m/s, high 3.0 m/s, ultra high 4.0 m/s
- Available for machine and material pallets
- Machine pallet sizes: from 400 x 400 to 800 x 800 mm
- One- or two-motor drive and modular structure for increased capacity
- Pallet handling with telescopic forks
- Maximum mast height 15 m

DMC-XMD Extra Medium Duty

- Load weight up to 2,500 kg
- Two different speed/performance classes: normal 2.5 m/s, high 3.0 m/s
- Available for machine and material pallets

- Machine pallet sizes: 630 x 630, 800 x 800 mm
- One- or two-motor drive and modular structure for increased capacity
- Sliding Height Measuring System for optimised space utilisation
- Pallet handling with telescopic forks
- Maximum mast height 16 m

DMC-HD Heavy Duty

- Maximum load weights of 3,500, 4,500 or 6,000 kg
- Available for machine and material pallets
- Machine pallet sizes: from 800 x 800 to 1,250 x 1,250 mm
- Pallet handling with telescopic forks
- Maximum mast height 12 m

DMC-XHD Extra Heavy Duty

- Maximum load weights of 7,500 or 10,000 kg
- Available for machine and material pallets
- Machine pallet sizes: 1,100 x 1,290 mm or more
- Pallet handling with telescopic forks
- Maximum mast height 10 m



DMC-MD Stacker Crane.

For different load types and sizes

DMC-MD/XMD/HD/XHD stacker cranes can be equipped with a fork pitch adjustment system option to enable the handling of different load types and load sizes with the same stacker crane. A rigid double mast construction guarantees stability and minimises mast deflection, which is essential when handling machine tool pallets.

Motion control of all three axes is integrated with frequency controlled AC drives, which ensures dynamic controllability. A regeneration unit allows minimal power consumption to be achieved in HD/XHD models.

Environmental protection and safety requirements are especially important elements in our engineering and product development work. For instance, all our stacker cranes are equipped with a drip tray for collecting coolant and chips.



DMC-XMD Stacker Crane with adjustable forks and a Sliding Height Measuring System.

A wide variety of loading and material stations

Fastems offers a wide range of FMS Loading Stations from which you can always find the right ergonomic solution to meet your specific needs.

FMS Loading Stations are a convenient and ergonomic solution for loading and unloading pallets. Designs range from compact stations up to height adjustable and tilting models.



LSF-LD/MD Loading Station

- Welded compact base frame with manually indexable revolving pallet table
- Also for manual flushing/washing
- Pallet sizes: 400 x 400, 500 x 500, 630 x 630 mm



LSM-MD/HD/XHD Loading Station

- Equipped with horizontal transfer
- Welded frame with pallet carriage for easy motorised pallet transfer between clamping area and stacker crane
- Revolving and indexable motorised pallet table
- Pallet sizes: from 500 x 500 and 630 x 630 up to 1250 x 1250 mm



LSL-MD/HD Loading Station

- Adjustable station height
- Equipped with combined horizontal and vertical transfer
- Revolving and indexable motorised pallet table
- Ergonomically correct working position when handling large pallets and work pieces



LST-MD/HD Loading Station

- Equipped with horizontal transfer and pallet tilt motion
- Ergonomically correct working position when handling pallets equipped with 4-face cube fixtures, for example
- Revolving and indexable motorised pallet table

FMS Material Pallet Stations are designed for handling material pallets and feeding them in and out of the system.

A variety of Material Pallet Stations are available depending on your needs.



MSP-LD/MD - Material Station

- Consists of a 4-wheel carriage with a pallet locator (installed on top)
- Freely movable carriage wherever material is needed
- Ideal for material picking and cell assembly



MSC - Material Station Conveyor IOC - Material Input Output Conveyor

- Consists of a fabricated steel frame with a motor-driven roller or chain conveyor
- MSC is ideal material station next to the loading station for automatic material delivery
- IOC designed for feeding in and taking out material pallets to/from storage



MSL - Material Station Lifting

- MSL takes your production one step further in terms of flexibility and it
- Allows the pallets to be positioned at the correct ergonomic height for the user
- Eliminates the need for trucks and other heavy equipment
- Can be integrated directly with both MD and HD systems
- Replaces conventional combinations of scissor lift tables, roll conveyors and trucks with a single, compact unit



MSB - Material Station

- Especially designed for use with loading stations
- Equipped with a motorised horizontal transfer to move the pallet between the stacker crane's pick-up area and the operator's working area
- Applicable for two-sided storage racks

Supplementary devices to complete your task



FMS Washing Station helps keep clamping areas clean and safe.

A full range of auxiliary equipment and interfaces allow you to complement your system with a variety of devices and functions. These devices will further help you in achieving the ultimate goal of 8760 annual production hours.



Automated Central Tool Storage, CTS, with Tool Gantry enables location of all spare tools in a central magazine and automates tool change to MC magazines from Central Tool Storage.



Tool Pre-setting Integration automates tool data transfer, tool data management and tool pre-setter integration.

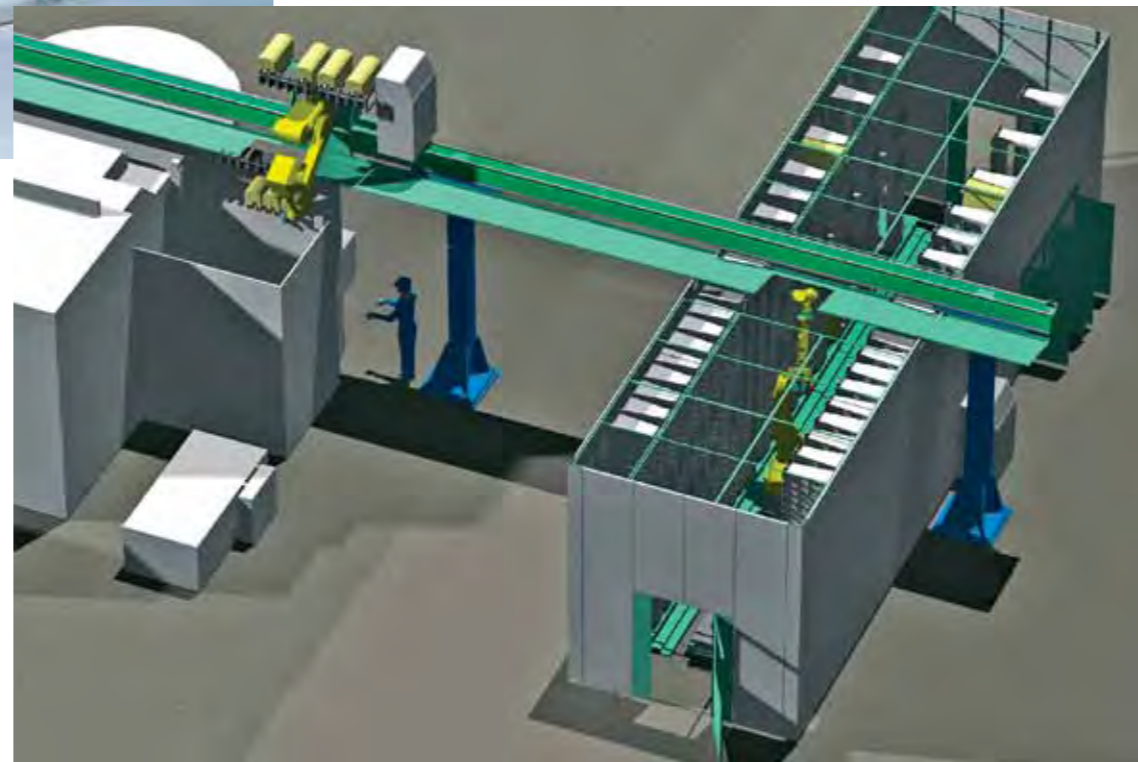

Fastems Central Tool Storage.



Fastems can supply high-quality machining pallets up to 1250 mm.

World-class services always at hand



As a leading supplier of factory automation, we at Fastems are fully aware of the challenges involved in your investment. Our comprehensive service portfolio aims at maximising the availability of your equipment by offering constant support in problem situations. Focused on growing local support, we are close enough to you to answer any question concerning our products and systems. In urgent matters, you can turn to our 24-hour Call Center.

Our Service Division supports all products delivered by our company. Our goal is to guarantee a high level of services that helps you achieve as much production capacity as possible.

Our service palette includes:

Contract services

- Spare parts
- Preventive maintenance

On call services

- Machine repair
- Fault service

Engineering services

- Control retrofits
- Spindle repair
- Mechanical retrofits

Expert services

- Teleservice
- Training
- Installation services

Start up services

Teleservice for quick assistance

Fastems Teleservice offers quick support for various problem situations via telephone, remote connections or e-mail. Teleservice is based on contracts with fixed annual fees. With it, you get unlimited support from our Teleservice crew, local service engineers or FMS design engineers.

You will gain through:

- Faster response times
- More accurate diagnosis
- Ability to resume production after troubleshooting

When you use the remote connection, our Fastems' experts have real-time access to your system. Our experts are able to use your MMS control, change parameters, view PLC inputs and outputs or even install new versions of the control program.

Remote alarm warns of errors

Connected to your FM system, the Remote Alarm application automatically warns of errors in system devices by e-mail or through SMS messages. It further allows users to request control data from FM systems using GSM phones and SMS messages.



Dial 8760 for an immediate response

For prompt advice on matters that cannot wait, you can simply dial **+358 8000 8760** for immediate assistance, or if no one is available you can leave us a message about the problem. All messages are documented and immediately dispatched to one of our service engineers who will help you without delay.

Just like our sales personnel, our service personnel are always within reach. You can contact your local service representative in Finland, Sweden, Germany, France, the United Kingdom, Italy and the USA.





Your dealer:



Fastems

FACTORY AUTOMATION

Fastems Oy Ab

Tuotekatu 4
FI-33840 Tampere, Finland
Tel. +358 (0)3 268 5111
Fax +358 (0)3 268 5000

Hakkilankaari 2
FI-01380 Vantaa, Finland
Tel. +358 (0)9 3450 48
Fax +358 (0)9 3450 5623

Fastems AB

Bultgatan 40 B
S-44240 Kungälv, Sweden
Tel. +46 (0)303 246 900
Fax +46 (0)303 246 910

Fastems GmbH

Heilbronner Straße 17/1
D-73037 Göppingen, Germany
Tel. +49 (0)7161-963 800
Fax +49 (0)7161 -963 8049

Branch office of Fastems GmbH

99, rue de Gerland
F-69007 Lyon, France
Tel. +33 (0)4 3765 2000
Fax +33 (0)4 3765 2001

Fastems

Iberica Automation S.L
Calle Moià, 1
E-08006 Barcelona, Spain
Tel. +34 932413704
Fax +34 934147036

Fastems K.K.

PBC, Shinjuku Maynds Tower 18 F
2-1-1 Yoyogi, Shibuya-ku,
Tokyo, Japan 151-0053
Tel. +81 3 5843 0075
Fax +81 3 5843 0070

Fastems LLC

9850 Windisch Road
West Chester,
Ohio 45069, USA.
Tel. 1 513 779 4614
Fax: +1 513 779 4638

Fastems Ltd

Hawley Mill-Hawley Road
Dartford, Kent DA2 7SY
United Kindom
Tel. +44 (0)7818 427133
Fax +44 (0)1322 282250

Liverpool Science Park
131 Mount Pleasant
Liverpool, L3 5TF
United Kingdom
Tel: +44 (0)151 705 3645
Fax: +44 (0)151 705 3410

Fastems S.r.l

Via Bruno Buozzi, 61
I-20097 San Donato
Milan (MI), Italy
Tel. +39 02 365727.23
Fax +39 02 365727.24

Fastems UAB

Kalvarijos str. 38
LT-46346 Kaunas, Lithuania
Tel. +370 37 291567
Fax: +370 37 291589